

BODY WORN CAMERA

MODEL: TB-MH2311/32G/GLE

Features

- 1080p HD recording.
- Max. 30 M (7296 × 4104) resolution of the captured picture.
- Transmits videos to central video platform via 4G wireless communication.
- Dual positioning modules of GPS and Beidou, uploading the location information to the center in real time.
- IR function to recognize the facial features in the captured picture even in dim environment.
- Waterproof, dustproof, and anti-fall with 1.8 m fall protection height, applicable to all-day field work.
- 3G/4G/Wi-Fi network connection with flexible wireless transmission.
- H.264 and H.265 encoding
- Full HD1080p@30FPS recording resolution
- 2.4 inch TFT LCD Touch screen
- Built-in IR illuminators, Built-in GPS and WIFI
- 32GB internal storage
- 3300mAh dismountable battery for 12 hours recording.
- Weight: 190 g
- Size: 95 × 60 × 29 mm
- Android 9.0 3G&4G

Product Image

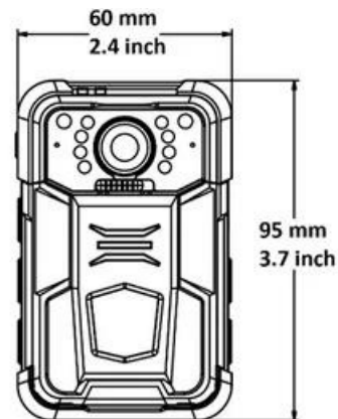

Specifications

Camera	
Image Sensor	1/3" progressive scan CMOS
Max. Resolution	1920 × 1080
Min. Illumination	Color: 0.15 Lux@ (F2.0, AGC ON), 0 Lux with supplement light
Zoom	4x Digital
Day & Night	Switch IR Cut Filter Automatically
White Light	Supported
Lens	
Focal Length	2.4 mm fixed lens
FOV	Horizontal FOV: 129°; Vertical FOV: 75°; Diagonal FOV: 154°
Aperture	F2.0
Video	
Video Compression	H.264, H.265
Video Format	PS, MP4
Main Stream	60 Hz: 30 fps (1920 × 1080, 1280 × 720, 720 × 576)
Sub Stream	30 fps (1280 × 720, 720 × 576)
Pre-record & Post-record	Pre-record: 60 s Post-record: 60 s
Audio	
Audio Compression	G.711ulaw, G.711alaw, G.722.1, AAC-LC
Audio Bit Rate	64 Kbps (G.711ulaw/G.711alaw), 16 Kbps (G.722.1/AAC-LC)
Image	
Image Format	JPEG
Screen	
Resolution	320 × 240
Screen Size	2.4"
Touchscreen	Supported
Storage	
RAM	2 GB
ROM	Default 32 GB, 64 GB/128 GB/256 GB optional
IR	
IR Range	Up to 10 m
IR Wavelength	850 nm
Wireless Network	
Bluetooth	BT4.2
Wi-Fi Protocol	802.11 a/b/g/n/ac
Wi-Fi Frequency Band	2.412 GHz to 2.472 GHz, 5.15 GHz to 5.25 GHz, 5.725 GHz to 5.875 GHz
Cellular Network	Only available for models with GLE : GSM: 850/900/1800/1900 WCDMA: B1/B8 FDD -LTE: B1/B2/B3/B4/B5/B7/B8/B20/B28 TDD -LTE: B38/B39/B40/B41
Positioning Mode	GPS



E111 FACTORY – THANH BINH BCA CO., LTD.

Industrial Zone – Lai Yen – Hoai Duc – Ha Noi

Tel: 1800-282229 | Email : info@tbvision.com.vn | Website : tbvision.com.vn |



Network	
Protocol	HTTPS, RTSP, NTP, FTP
API	ONVIF (PROFILE S, PROFILE G, PROFILE T), ISAPI, SDK, ISUP5.0
Interface	
Indicator	2 Indicator(s) for Charging/Working/Recording/Exception
Button	Power, Recording, Tag, SOS, Fn, PTT, Capture
SIM Card	Only available for models with /GLE: 1 (Nano-SIM)
Charging Interface	Mini USB, Pogo Pin
USB	USB 2.0
Laser Positioning	Supported
General	
Operating Condition	-20 °C to 55 °C (-4 °F to 131 °F). Humidity 95% or less (non-condensing)
Power	5 VDC, 2.0 A, max. 10 W
Dimension	95 mm × 60 mm × 29 mm (3.7" × 2.4" × 1.1")
Weight	190 g (without mounting) (0.4 lb.)
Operating System	Android 9.0
Client	VIMS software
MIC	Supported
Speaker	1 Built-in speaker, Max. power consumption: 1 W, Max. sound pressure level: 92 dB (10 cm)
Battery	
Battery Type	Lithium-ion battery, dismountable
Capacity	3300 mAh
Charging Time	≤ 4 h
Battery Duration	≥ 11 h in 720p resolution
Approval	
RF	EN 300 328 V2.1.1 (BT or 2.4G); EN 62311: 2008 (BT or 2.4G); EN 55032: 2015; EN 61000-3-2: 2014; EN 61000-3-3: 2013; EN 50130-4: 2011 + A1: 2014);
EMC	CE-EMC: EN 55032: 2015, EN 61000-3-2: 2019, EN 61000-3-3: 2013, EN 50130-4: 2011 + A1: 2014
Safety	CB: IEC 62368-1: 2014+A11, IEC 62368-1: 2018 CE-LVD: EN 62368-1: 2014/A11: 2017, EN IEC 62368-1: 2020 + A11: 2020 CE-LVD: EN 62368-1: 2014/A11: 2017
Environment	CE-RoHS: 2011/65/EU, WEEE: 2012/19/EU, Reach: Regulation (EC) No 1907/2006
Protection	IP67: IEC 60529-2013, MIL STD 810G



E111 FACTORY – THANH BINH BCA CO., LTD.

Industrial Zone – Lai Yen – Hoai Duc – Ha Noi

Tel: 1800-282229 | Email : info@tbvision.com.vn | Website : tbvision.com.vn |



Battery (Included 01 pcs)



Capacity: 3300mAh
Type: Li-ion
Voltage: 3.8V
Rate: 12.54Wh
Color: Black

Metal clip TB-MH1710-N1-S



Body material: plastic
Color: Black
Self Weight : 30g
109*51*14.5mm

Charger TB-MH1411-N1



Power Supply: 5.4 VDC/2.2 A
Charging Current: 500 mA
Charging Duration: Approx. 8 hours
(connected with dock station), Approx. 3
hours without host (connected with
adaptor),
Indicator Status: